

Models available : **TM-9200s-U240n-5A**
***TM-9300s-U240n-5A**
TM-9200s-D24n (DC 16 V~36 V)
***TM-9300s-D24n (DC 16 V~36 V)**

NUMERICAL BASED TM 9200S LTI TM 9300S IDMT OVER CURRENT RELAY FEATURES



- True RMS measurement
- Low / High set
- Operation hour recording
- Fault / Trip LED indication
- 3-tripping history
- Neutral current display
- THD-I display
- Last 30 min. ampere demand
- Maximum ampere demand
- 2 selectable characteristics (DTL / LTI)
- *7 selectable characteristics
- 2 output relays
- Auto shorting of CTs (when unplugged)
- Programmable software lock
- Flush mount

(*): Available for IDMT models only

IDMT GRAPH

Time graph based on Time Multiplier 1.0

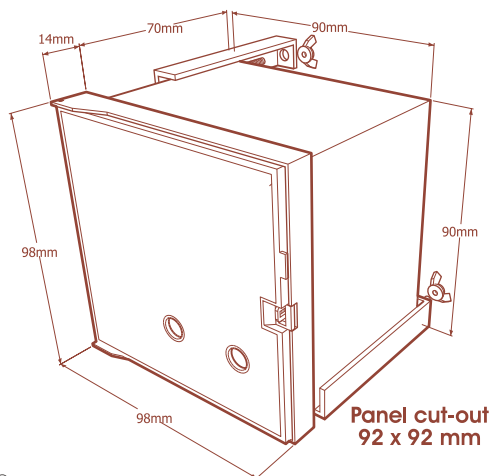
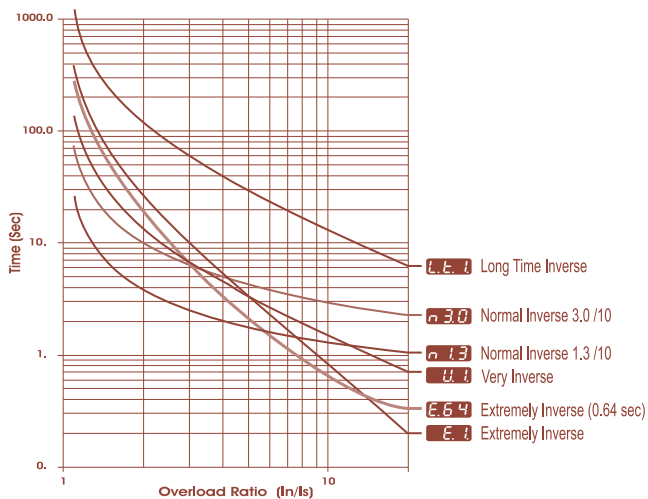

TECHNICAL DATA

Measurement	True RMS Ampere
Power supply	85 ~ 270 VAC / 100 ~ 340 VDC 16 ~ 36 VDC (model : D24n)
Rated current	.. /5A , .. /1A upon request
Rated frequency	50 / 60 Hz (selectable)
Relay operation level	$\geq 1.10 \times (\text{IDMT})$, $\geq 1.0 \times (\text{DTL})$
C.T. burden@5A	< 0.5 VA
Tripping contact	SPDT 5A / 240 VAC
Weight	approx. 500 g
Operating temp.	0° C ~ +55° C
Standard	IEC : 61000-4-2/4-4/4-5/255-5:1

SETTING RANGE

Current Setting	20 ~ 200% (1% step)
High-set	20 ~ 2000% (10% step) or OFF
Time setting	0.05~1.00 (0.01 time multiplier step) 0.05 ~ 20.0 (0.1 sec step)
High-set time	0.03~ 20.0 (0.1 sec step)

WIRING DIAGRAM

