

NUMERICAL BASED TM 8200S DTL TM 8300S IDMT EARTH FAULT RELAY

FEATURES



- True RMS measurement
- Low set
- High set
- Operation hour recording
- Fault & Trip LED indication
- Trip value recording (3 memory)
- *Selectable 6 IDMT graphs
- Programmable relay output
- Programmable software lock
- Flush mount

(*) : Available for IDMT models only

IDMT GRAPH

Time graph based on Time Multiplier 1.0

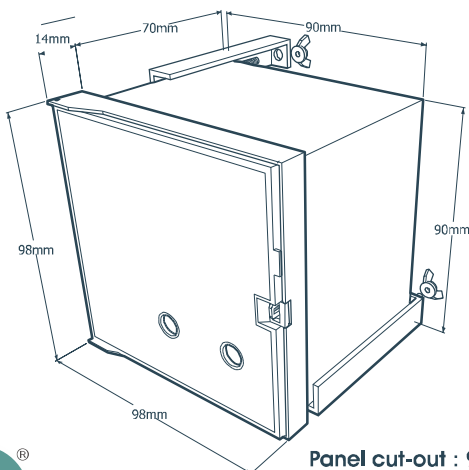
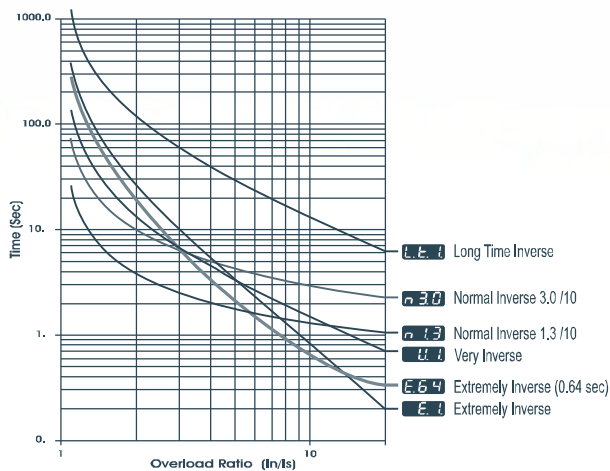

Panel cut-out : 92 x 92 mm

TECHNICAL DATA

Measurement	True RMS Ampere
Power supply	240 VAC
Rated current	..,5A
Rated frequency	50 / 60 Hz (selectable)
Relay operation level	$\geq 1.10 \times$ (IDMT), $\geq 1.0 \times$ (DTL)
C.T. burden@5A	< 0,5 VA
Tripping contact	SPDT 5A / 240 VAC
Weight	approx. 450 g
Operating temp.	0° C ~ +55° C
Standard	IEC : 61000-4-2/4-4/4-5/255-5:1

SETTING RANGE

Current Setting	2% ~ 50%
High-set	OFF or 20% ~ 990%
Time setting	0.05~10.0 (DTL model)
	0,05 ~ 1,00 (time multiplier) IDMT model
High-set time	30 ms Fixed (DTL model)
	0.03 ~ 10.0 (IDMT model)

WIRING DIAGRAM

