



RPR415

Features

- Reverse power monitoring
- 3-phase-4-wire system
- Adjustable reverse power setting
- Adjustable tripping time delay
- Indicators for auxiliary power, trip delay and trip status
- Test button

TYPICAL APPLICATION DIAGRAM

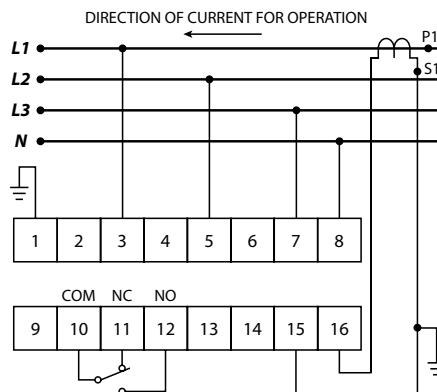

Product Description

The RPR 415 relay is a directionally controlled timing relay used to protect AC generators from motoring. When such a condition occurs and the reverse current exceeded the customer adjustable preset limit and the current persists for a predetermined delay time, the trip relay operates to disconnect the circuit.

Technical Data

INPUT

Rated voltage (U_N) : 380 ~ 440 V AC
 Rated current (I_N) : 5 A
 Rated frequency : 50 Hz / 60 Hz
 Overload : $1.2 \times U_N, 2 \times I_N$ continuous
 $1.2 \times U_N, 10 \times I_N$ for 3 sec

OUTPUT

Contact Arrangement : Change-over
 Contact rating : 5 A, 250 V AC ($\cos \varphi = 1$)
 Contact material : Silver alloy
 Expected electrical life: 100,000 operations at rated current
 Expected mechanical life: 5×10^6 operations

SETPOINT

Range : 2% to 20% reverse current
 Time delay : Adjustable 0 sec to 20 sec
 Hysteresis : 1%
 Repeatability : 0.5%

ENVIRONMENTAL CONDITIONS

Temperature : -5°C to $+55^\circ\text{C}$
 Humidity : 56 days at 93% RH and 40°C non-condensing

CASE DIMENSIONS

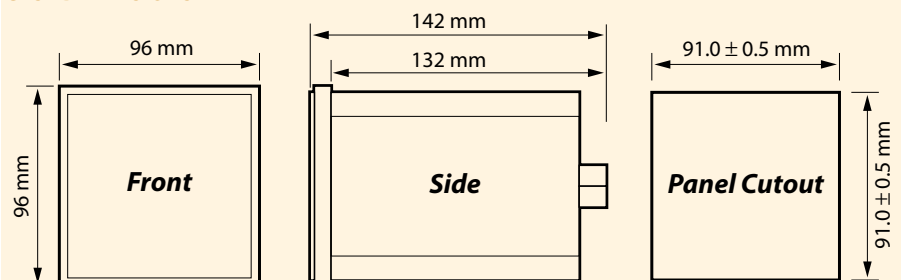

Ordering Information

MODEL	DESCRIPTION
RPR415	Auxiliary voltage 380 ~ 440 V AC

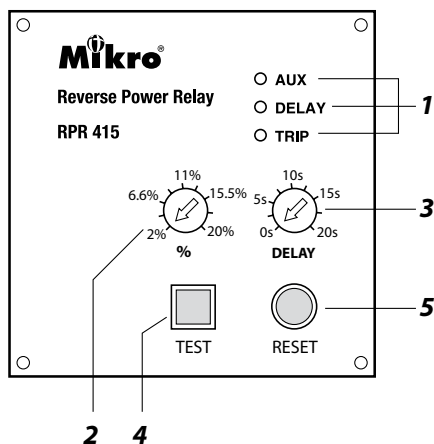

Front Panel Description

1. Light Indicators

Indicator AUX	Indicator DELAY	Indicator TRIP	Status
OFF	OFF	OFF	No auxiliary power supply.
ON	OFF	OFF	System normal mode. No tripping.
ON	ON	OFF	Reverse current exceeded pre-set limit. Time delay countdown started.
ON	OFF	ON	System tripped.

2. Reverse Current Adjustment Knob

- For setting the minimum reverse current before tripping
- Setting range from 2% to 20%

3. Delay Timing Adjustment Knob

- Trip time delay setting
- Setting range from 0 to 20 sec

4. Test Button

- Press the test button to simulate a trip condition.

5. Reset Button

- The reset button is for resetting the light indicator after tripping.
- To reset, press the reset button once
- The tripping contact will be released once the reverse current fall below the pre-set limit. However, the TRIP light indicator is latched. Press the reset button to reset the light indicator to normal state.