



# MK2200

## Introduction

The MK2200 combined overcurrent and earth-fault relay is a digital microprocessor based relay. This relay employs extensive advance numerical techniques implemented in real-time, for the computation of measured input quantity. Other advance features include programmable control output, metering and fault data recording.

## Application

The MK2200 combined overcurrent and earth-fault relay is used where time graded overcurrent and earth fault protection is required.

## Features

- Multifunction numerical relay
- Three-phase, low-set and high-set phase overcurrent
- Two sets of low-set and high-set setting for phase overcurrent
- Low-set and high-set earth fault
- Two sets of low-set and high-set setting for earth fault
- Four selectable IDMT characteristic curves
- Definite time for low-set and high-set
- Numeric display of phase and earth fault currents
- Display of relay settings
- 9 non-volatile records of previous trip-ping currents
- Recording of relay start time
- Highly flexible programmable relay outputs
- Multifunction external digital input
- Isolated RS485 Modbus - RTU communication
- Selectable 50 Hz / 60 Hz

## Functions

### 1 Phase Overcurrent Protection

When the phase current exceeds the low-set  $I>$  setting value, the overcurrent low-set element starts and delivers a start signal to the display panel and a group of preassigned relay outputs. After a delay time, determined by the inverse time current characteristic curve selected and the measured current or by definite time  $t>$ , this overcurrent element operates and delivers a trip signal to the display panel and a group of relay outputs that are configured to link to the low-set phase overcurrent tripping.

When the phase current exceeds the high-set  $I>>$  setting value, the overcurrent high-set element starts and delivers a start signal to the display panel and a group of preassigned relay outputs. After a preset time, determined by  $t>>$ , this overcurrent element operates and delivers a trip signal to the display panel and a group of relay outputs that are configured to link to high-set phase overcurrent tripping.

### 2 Earth-Fault Protection

When the earth-fault current exceeds the low-set  $I_0>$  setting value, the earth-fault low-set element starts and delivers a start signal to the display panel and a group of preassigned relay outputs. After a delay time, determined by the inverse time current characteristic curve selected and the measured current or by definite time  $t_0>$ , this earth-fault element operates and delivers a trip signal to the display panel and a group of relay outputs that are configured to link to the low-set earth-fault tripping.

When the earth-fault current exceeds the high-set  $I_0>>$  setting value, the earth-fault high-set element starts and delivers a start signal to the display panel and a group of preassigned relay outputs. After a preset time, determined by  $t_0>>$ , this earth-fault element operates and delivers a trip signal to the display panel and a group of relay outputs that are configured to link to high-set earth-fault tripping.

### 3 Low-set Characteristic Curves

The inverse definite minimum time (IDMT) characteristic curves in MK2200 comply with BS142-3 and IEC60255-3. The selectable curves and characteristics are:

- Normal inverse
- Very inverse
- Extremely inverse
- Long-time inverse
- Definite time

### 4 High-set Characteristic

The high-set is selectable between definite time and instantaneous tripping characteristic.

### 5 External Binary Input

The functions of the external binary input are:

- Blocking the operation of one or more protection stages.
- Remote trip reset.
- Changing of protection group settings.
- Tripping the MK2200 by an external device.

### PHUONGLAI<sub>n</sub>

### 6 Relay Output

There are five relay outputs that can be programmed to respond to the relay start signal, the trip signal, or both the start and trip signals. The sixth relay output functions as internal relay failure indicator.

### 7 Configuration

The configuration of the relay is accomplished by software switches settable by the user from the front panel.

### 8 Metering and Fault Record

This function enables the values of the phase current and the earth-fault current to be viewed by the user. In addition, the user can also view the measured values of the phase current and earth-fault current recorded at the moment of fault for the previous 9 fault records stored in non-volatile memory.

## Technical Data

### INPUTS

#### Measuring input:

Rated current In : 1 A or 5 A  
 Rated frequency : 50 or 60 Hz  
 Thermal withstand : 4 x In continuous  
                               25 x In for less than 10 sec  
                               100 x In for less than 1 sec  
 Burden : < 0.3VA at In

#### Rated auxiliary voltage:

Model MK2200-150D : 24~150 V DC  
 Model MK2200-240A : 198~265 V AC  
 Model MK2200-240AD : 85~265 V AC  
   110~340 V DC

#### Power consumption:

AC auxiliary voltage : 6 ~ 10 VA typical  
 DC auxiliary voltage : 5 ~ 9 W typical

#### Binary Input:

External binary input : 18 ~ 265 V DC  
   85 ~ 265 V AC

### EARTH-FAULT ELEMENT

Low-set setting I o> : 0.05 ~ 1.0 x In , step 0.01  
 High-set setting I o>> : 0.05 ~ 10.0 x I step 0.05  
 Time multiplier kt o> : 0.02 ~ 1.0 , step 0.01  
 Low set definite time t o> : 0 ~ 300 s } 0 ~ 10.0s : step 0.01  
 High set definite time t o>> : 0 ~ 300 s } 10.0 ~ 100s : step 0.1  
   100 ~ 300s : step 1

### OVERCURRENT ELEMENT

Low-set setting I > : 0.10 ~ 2.50 x In , step 0.01  
 High-set setting I >> : 0.10 ~ 40 x In , step 0.05 ( 0.1 ~ 10 In ),  
   step 0.1 ( 10 ~ 40 In )  
 Time multiplier kt > : 0.02 ~ 1.0 , step 0.01  
 Low set definite time t > : 0 ~ 300 s } 0 ~ 10.0s : step 0.01  
 High set definite time t >> : 0 ~ 300 s } 10.0 ~ 100s : step 0.1  
   100 ~ 300s : step 1

### COMMUNICATION

RS485 Modbus - RTU

### OUTPUTS

#### 5 programmable contacts +1 IRF contact:

Rated voltage : 250 V AC/DC  
 Continuous carry : 5 A  
 Make and carry for 0.2 s : 30 A

#### Contact specification:

Expected electrical life : 10<sup>5</sup> operations  
 Expected mechanical life : 5 x 10<sup>6</sup> operations

### ACCURACY

Protection thresholds : ± 3%  
 Time delay : ± 2% with a minimum  
   of 30 ms  
 Measurements : ± 3%  
 Reset ratio : 95% typical  
 Overshoot time : less than 30 ms typical

### ENVIRONMENTAL CONDITIONS

Temperature : -5°C to +55°C  
 Humidity : 56 days at 93% RH and 40°C  
   non-condensing

## Tests And Standards

High voltage dielectric withstand test IEC60255-5	2.0 KV rms, 1 min
High voltage impulse test IEC60255-5	5 KV, 1.2/50µs
Electrical fast transient IEC61000-4-4, Level 4, power supply inputs	4 KV, 5/50ns
Electrical fast transient IEC61000-4-4, Level 4, other inputs	2 KV, 5/50ns
Electrostatic discharge IEC61000-4-2, Class III, air discharge	8 KV
Electrostatic discharge IEC61000-4-2, Class III, contact discharge	6 KV
1MHz Burst Disturbance IEC60255-22-1	2 KV Common mode 1 KV Differential mode
Enclosure protection when panel mounted	IP54

**NORMAL INVERSE**

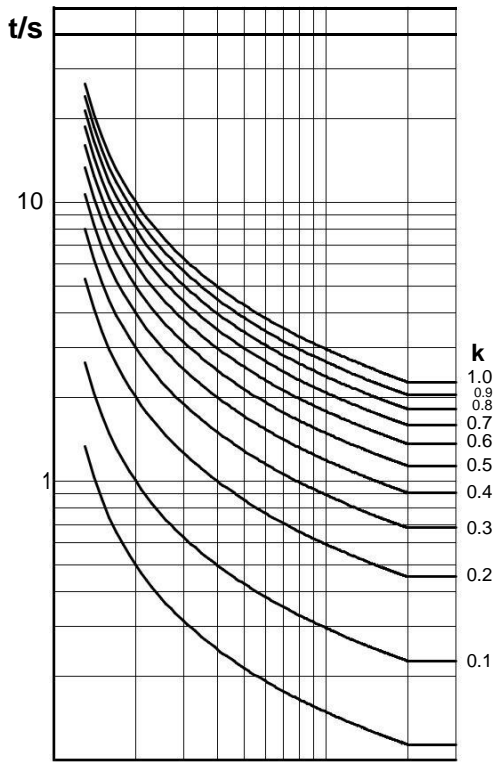

**VERY INVERSE**

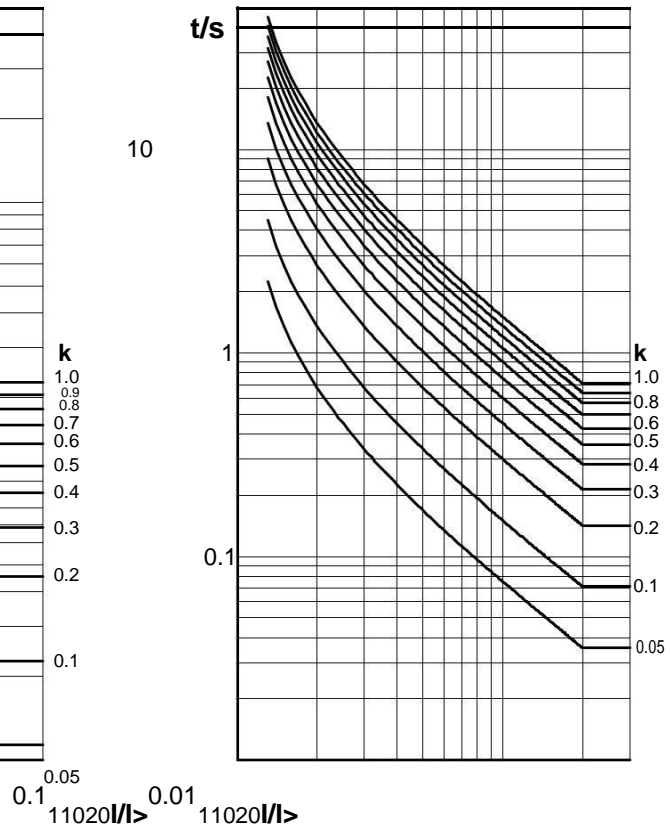

**EXTREMELY INVERSE**

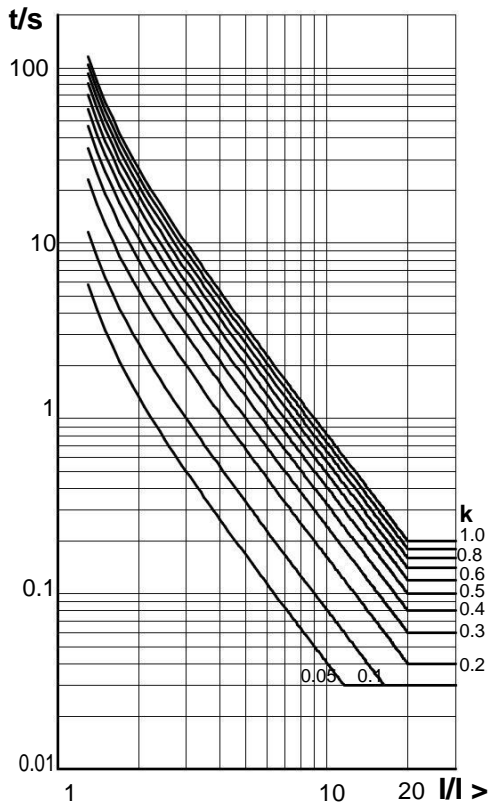

**LONG-TIME INVERSE**

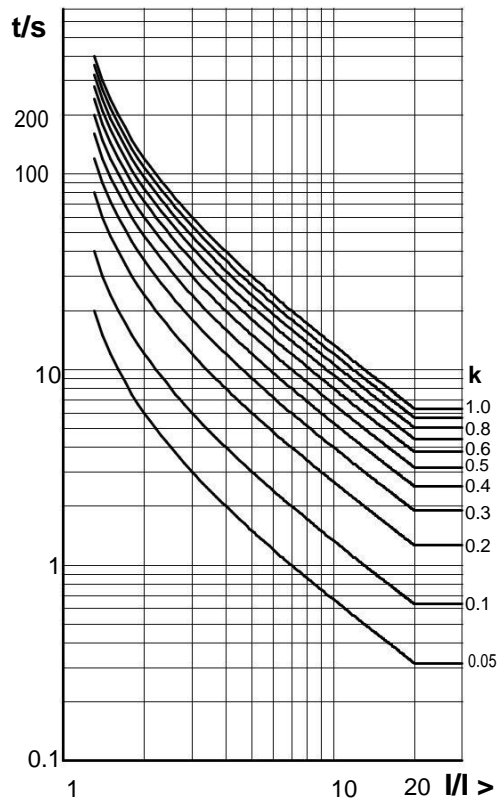

## TYPICAL APPLICATION DIAGRAM 1

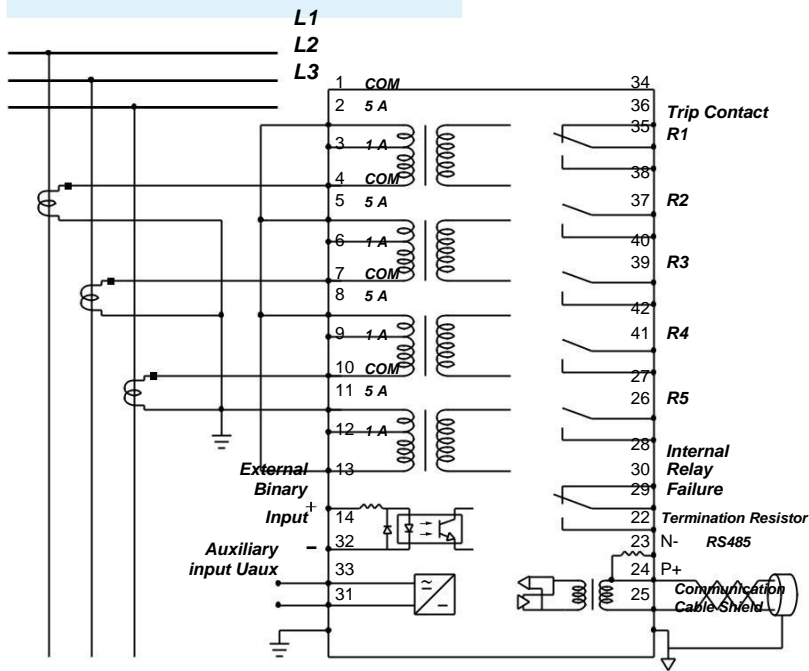

## TYPICAL APPLICATION DIAGRAM 2

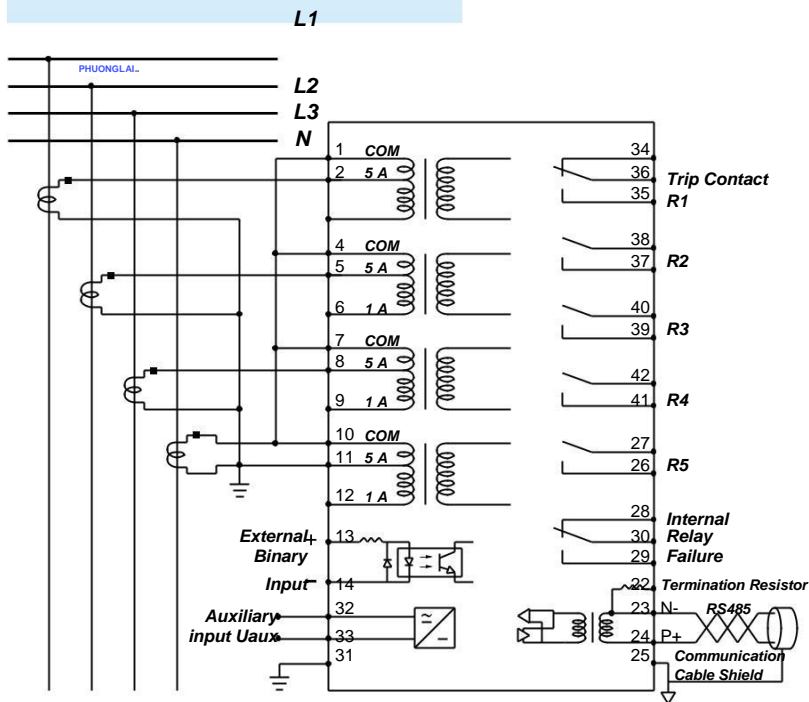

## CASE DIMENSIONS

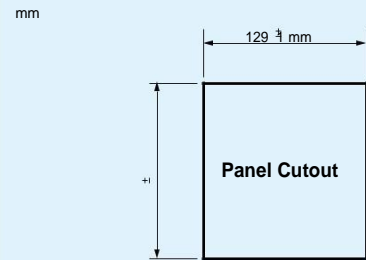
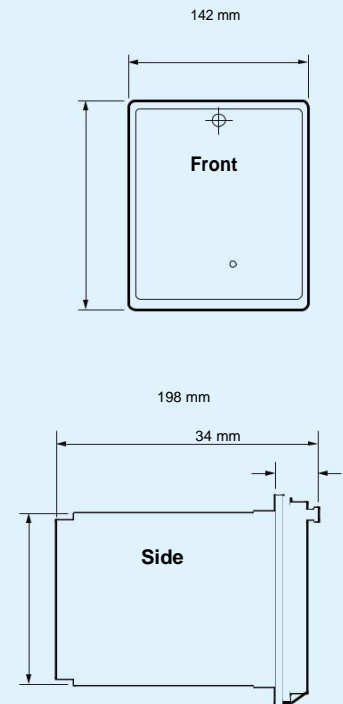

## Ordering Information

MODEL	DESCRIPTION
-------	-------------

MK2200 - 150D	For 50/60 Hz system, auxiliary voltage 24 ~ 150 V DC
MK2200 - 240A	For 50/60 Hz system, auxiliary voltage 198 ~ 265 V AC
MK2200 - 240AD	For 50/60 Hz system, auxiliary voltage 84 ~ 265 V AC or 110 ~ 340 V DC

